

## Turning An Acorn Birdhouse

### Overview

An acorn birdhouse makes an attractive table or Christmas tree ornament. It can be turned from oak or a variety of contrasting woods and enhanced by gluing a small bird on its perch.

I spend approximately one hour turning the birdhouse, from roughing out the blanks to buffing the finished piece.

I turn the body of the birdhouse first, and then turn the roof. After I finish the inside and outside of the rood and before I turn it off, I glue the body to the roof and turn the finial on the bottom of the body. After removing the birdhouse from the lathe, I drill the entrance and perch holes. Before attaching the perch, I finish the birdhouse with an oil/varnish mix, and buff it with Tripoli, white diamond

compound, and carnauba wax. The final touches include attaching a 1/8" brass screw eye at the top and gluing a 1/2" bird to the perch.

### Design Overview

This acorn birdhouse design is based on the proportions of a white oak acorn enlarged approximately 400 percent.

The design can be adapted for a red oak acorn, which typically has a squatter body. There are several design elements I have used with my acorn birdhouses:

- Texturing the roof
- Turning a multi axis perch
- Adding color
- Adding beads to the bottom

Cedar



Oak



## Materials

3" diameter wood  
2 1/4" diameter wood  
CA cement  
180, 240, 320, and 400 grits sand paper  
Sanding sealer  
Oil/varnish  
Paper towel  
1/8" screw-eye  
1/2" bird  
Waste wood for perch

## Tools

3/4" roughing gouge  
3/8" spindle gouge  
1/4" skew chisel  
5/16" drill bit  
1/16" drill bit  
1/8" parting tool  
9/32" drill bit (small birdhouse)

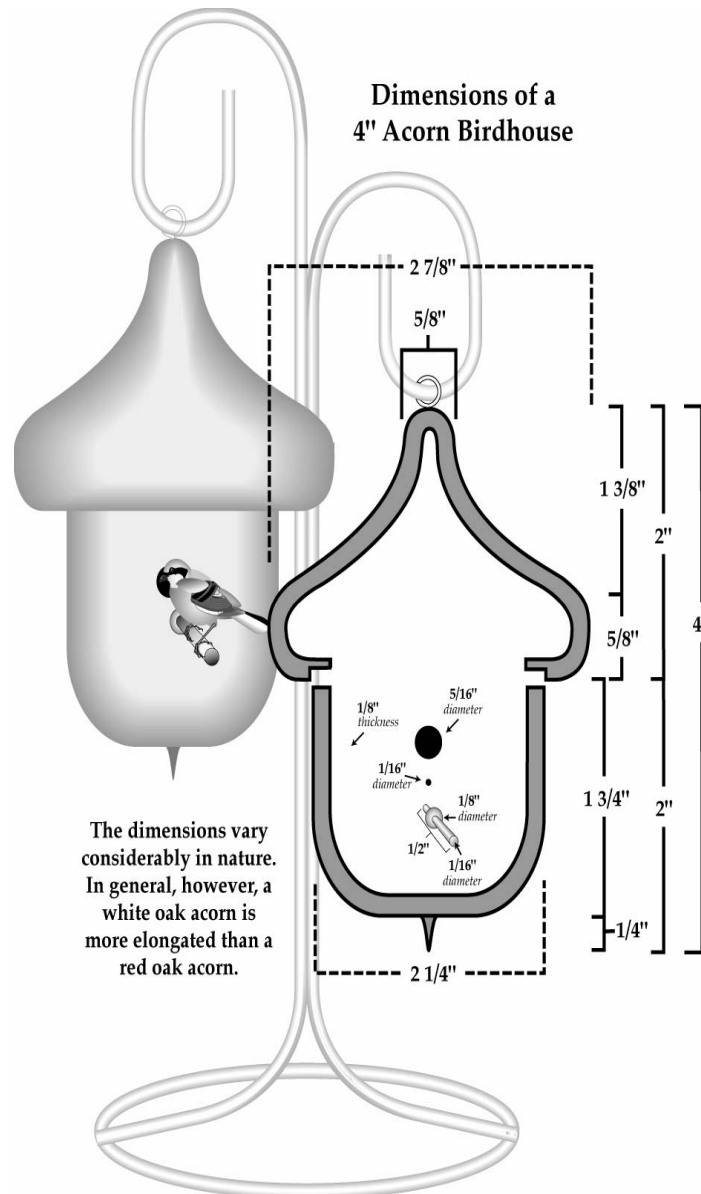

## *Turning the Birdhouse Body*

1. Rough out a blank to about  $2\frac{1}{4}$ " in diameter and at least 3" long. I often use an 8" long blank and turn three birdhouse bodies at a time.
2. True up both ends of the blank.
3. Turn a tenon at one end of the blank  $1\frac{3}{4}$ " in diameter and  $\frac{3}{8}$ " wide.

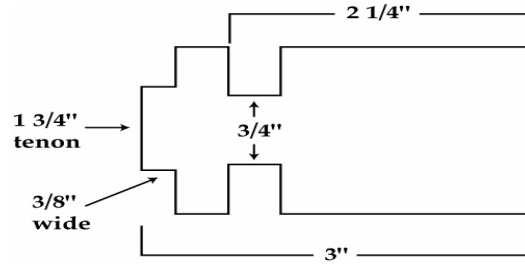

4. Chuck up the blank.
5. Mark off a  $2\frac{1}{4}$ " section on the length of the blank and with a parting tool cut to a depth of  $\frac{3}{4}$ ". This leaves  $\frac{1}{4}$ " of extra space to turn the 2" bottom and finial.
6. Shape the outside of the body. Leave the finial area about  $\frac{3}{4}$ " in diameter for support while hollowing out the interior.

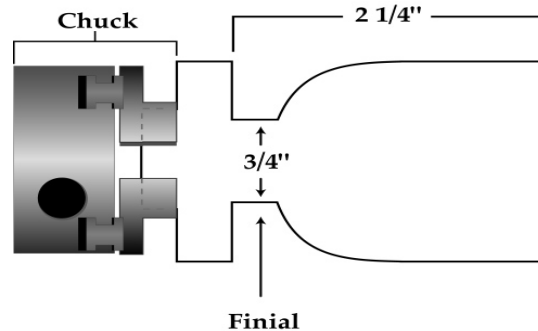

7. Sand the body and apply sanding sealer and wipe off the excess.
8. Hollow out the interior of the body, leaving  $\frac{1}{16}$ " to  $\frac{1}{8}$ " thick sides and  $\frac{3}{16}$ " to  $\frac{1}{4}$ " bottom thickness.
9. Apply sanding sealer to the interior of the body.
10. Refine the bottom and reduce the finial to  $\frac{1}{4}$ " in diameter.
11. Sand the bottom of the body.
12. Part off and apply sanding sealer.
13. If using an 8" blank, repeat steps 5-12 for the second and third birdhouse bodies.

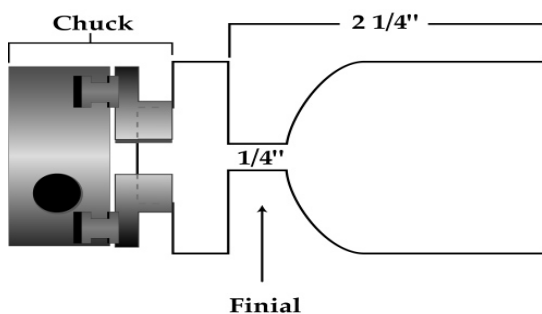

I use a paper towel to wipe off sanding sealer and oil/varnish, because if it catches, it will tear and not harm the turner or turning.

## ***Turning the Birdhouse Roof***

1. Rough out a blank to about 3" in diameter and at least 3" long. As with the body, I often use a 8" long blank and turn three birdhouse roofs at a time.
2. True up both ends of the blank.
3. Turn a tenon at one of the blank 1 $\frac{3}{4}$ " in diameter and 3/8" inside.

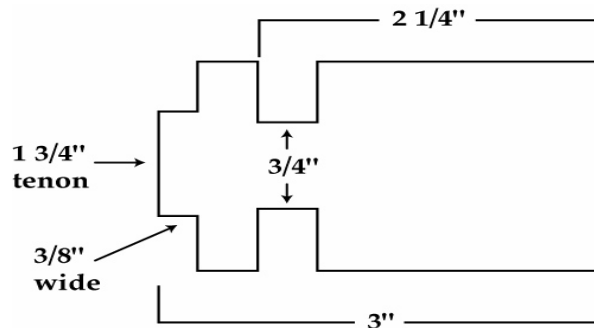

4. Chuck up the blank.
5. Mark off a 2 1/4" section on the length of the blank and with a parting tool cut to depth of 3/4". This leaves 1/4" of extra space to turn the 2" top.
6. Shape the outside of the roof. Leave the finial area about 3/4" in diameter for support while hollowing out the exterior.

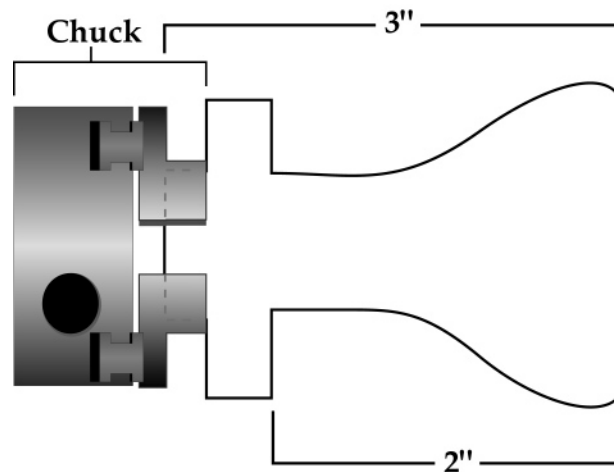

7. Measure the diameter of the previously turned body and scribe a circle on the bottom of the roof to match it.
8. Cut a 1/8" wide flange 1/4" deep on the inside of the roof with a 1/8" parting tool or 1/4" skew chisel, check to see that the body fits tightly into the roof.
9. Once the flange has been sized to fit the body, remove the bulk of the waste from the inside of the roof with a 3/8" spindle gouge leaving the 1/8" flange.

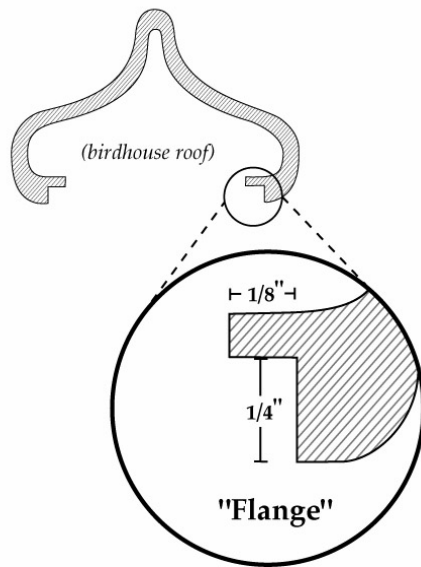

I use a scraper to remove wood from behind the flange.

10. Refine the outside of the roof, reducing the finial to 1/2" diameter.
11. Sand the outside of the roof and apply sanding sealer.
12. Refine the interior of the roof leaving 1/8" to 3/16" thickness in the sides and apply sanding sealer.
13. Glue the body to the roof.
14. Finish turning the small finial on the bottom of the body.
15. Sand the finial and apply sanding sealer.
16. Finish the finial on the top of the roof.
17. Sand the finial on the top of the roof and apply sanding sealer.
18. Part off the roof.
19. Hand sand the top of the finial and apply sanding sealer.
20. Repeat steps 5-19 for the second and third roof if using a 8 1/4" long blank.
21. Drill a 5/16" entrance hole in the upper part of the body.
22. Drill a 1/16" hole below the entrance hole for a perch.
23. The perch is 1/16" in diameter and 5/8" long turned from waste with 1/4" skew chisel and sanded.
24. Screw a 3/16" screw-eye into the top of the roof.

## General Finishing Information

1. Sand to a 320 or 400 grit finish.
2. Apply sanding sealer (Alkyd Resin).
3. Wipe sanding sealer off immediately and sand when dried.
4. Apply oil/varnish finish after sealer has dried, wipe with paper towel.
5. After finish has cured, buff with:
  - A. Tripoli
  - B. White diamond compound
  - C. Carnauba wax
6. If you prefer a lacquer finish, you should use a lacquer sanding sealer rather than the Alkyd Resin sealer.

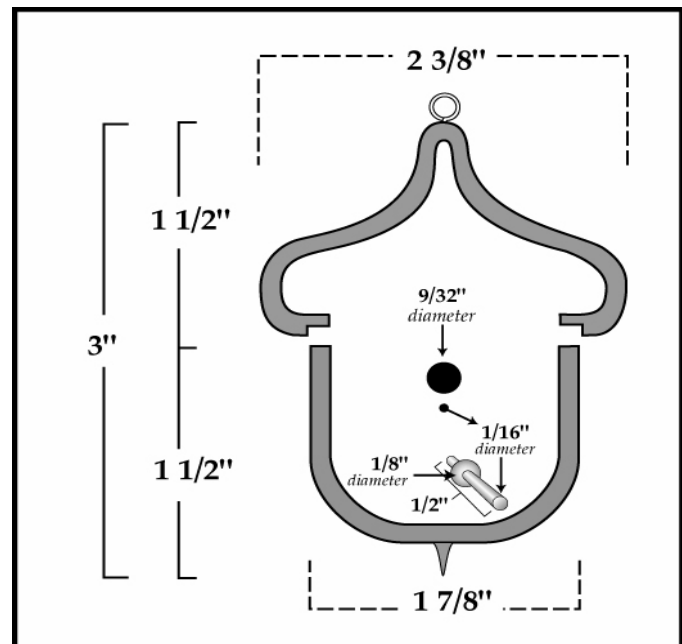
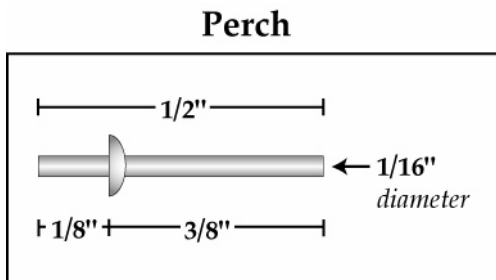

**Dimensions of a 3" Acorn Birdhouse**