

## Turning and Detailing Platters

### Introduction

Platters offer an excellent opportunity for you to express yourself creatively. There are an infinite variety of designs and detailing that can be used with platters. These instructions will provide a basic introduction to turning platters. Once you have mastered the basics, let your imagination soar.

#### Tool:

3/8" bowl gouges-fingernail and traditional grind.

1/4 skew chisel

1/4" Pyramid tool/3 point tool

Texturing tool

### I. Select Platter Blank

1. Dry wood, preferably kiln dried, wood is recommended to prevent warping.
2. The blank should be at least 11" in diameter and 2" thick. I like to turn 17" platters.
3. Check the wood for defects as well as character.
4. Make sure that the most interesting side of the wood is used for the face of the platter. This is the side to which the faceplate or screw chuck will be attached.

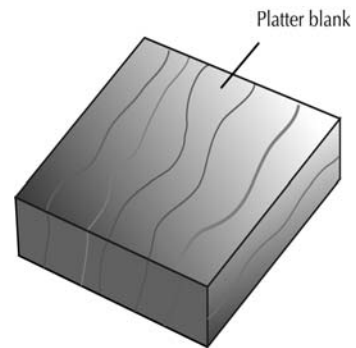

### II. Preparing the Blank

1. Plan at least one face of the blank, if uneven, so that the faceplate or screw chuck will sit evenly on the blank.
2. Draw a circle on the blank with a compass to determine the largest diameter possible.
3. Mark the center point to make it easier to align the faceplate in the center of the blank. You will need to drill a hole in the center if you are using a screw chuck,
4. Cut out the circle on the band saw in order to facilitate turning the blank on the lathe.
5. Screw one 3" or 4" faceplate with #10 machine screws 1" long. A blank larger than 15" will require a 6" faceplate.
6. Mount the blank on the lathe.
7. True up the edge and face of the blank.

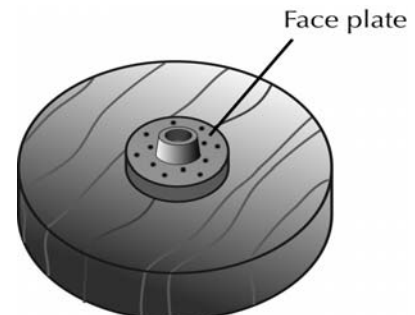
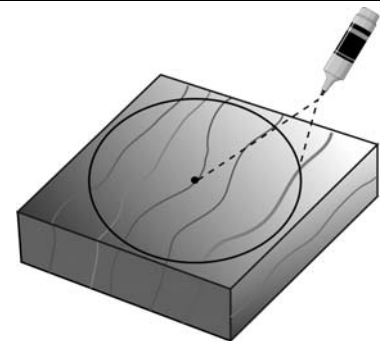

### III. Preparing the Recess and Foot

1. Draw 4½" and 6½" circles in the center of the face of the blank to create a 1" wide band.
2. The draw a 5½" dotted circle in the center of 1" band.
3. Divide the 1" wide band into three sections. Use the radius of the 5½" dotted circle to divide the band into thirds.
4. Mark a line ¾" on both sides of the three points on the band.

The radius of a circle is equal to 1/6" the circumference.

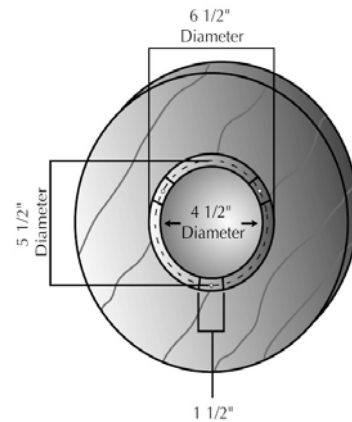

### IV. Turning the Foot and Bottom of the Platter

1. Recess the 4½" diameter circle to a depth of 3/16". This will be used for expansion chucking the blank.
2. Rough turn the shape of the rest of the bottom of the platter from the 6½" circle to the edge of the blank. Create a slight ogee near the edge of the blank.
3. Carve the three legs in the foot of the platter in the 1" band. I use a reciprocating carver and 1" drum sander.
4. Refine the shape of the platter.
5. Sand the recess, foot and bottom of the platter to 400 grit.
6. At this point you may choose to detail the foot, bottom and or recess of the platter.
7. Carefully fine sand (600 grit) any detailing.
8. Apply the finish of your choice.
9. Remove the blank from the lathe.
10. Remove the faceplate from the blank.



I like to use a 3/8" bowl gouge with a fingernail grind using a pulling and slicing cut to shape the back of the platter. I find I get less tear out this way. I use a 3/8" bowl gouge with an English grind for my finishing cuts.

### V. Turning the Front of the Platter

1. Remount the blank on the lathe by expanding the chuck jaws into the recess in the foot of the platter.
2. True up the face of the platter.
3. If you are planning to detail the rim of the platter, you should first turn about 2" of the rim of the platter.

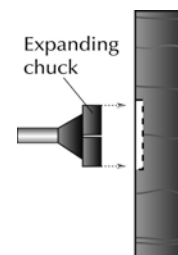

- Leave the wood in the center of the platter.  
This will help stabilize the rim for detailing.
- Turn the 2" area down to about 3/16" thick.
  - Sand the rim area.
  - Detail the rim and finish sanding the detailing. I like the combination of beads and texturing.
  - Turn the remaining center of the platter making sure the center is flat.
  - Sand the platter to a 600 grit and apply a finish.

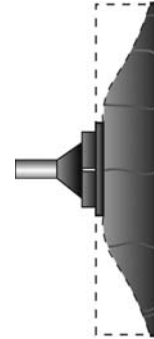

I prefer to finish turning the foot and the back of the platter before I turn the front of the platter. If you do not want to recess the foot for expansion chucking, you can use an Oneway jumbo jaws or MDF board to rechunk the platter to turn the foot.

## VI. Prepare a Jam Chuck {to finish the foot of the platter}

- Cut a square piece of MDF board at least 3/4" larger than the platter.
- Draw as large as circle as possible with a compass.
- Mark the center for easier alignment of the faceplate.
- Cut out the circle on the band saw.
- Screw on a 3" faceplate with #10 machine screws 3/4" long.
- Mount the MDF jam chuck on the lathe.
- True up the edge of the MDF blank in the same manner as the platter blank.
- Mark out the diameter of the platter on the MDF blank with a pair of calipers.
- Turn a 1/2" recess for the platter on the MDF blank.

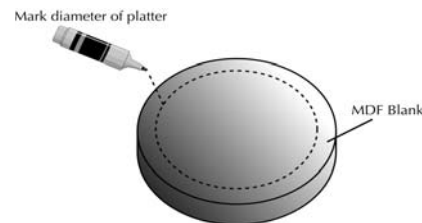
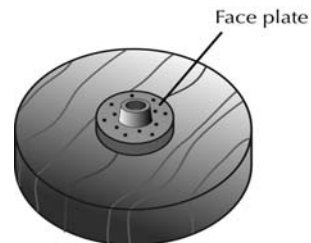

## VII. Turning the Platter Foot

- Jam chuck the platter into the recess on the MDF blank, making sure the platter fits snugly.
- Turn the foot for the platter-this is an opportunity to be creative.
- Add beads, if desired.

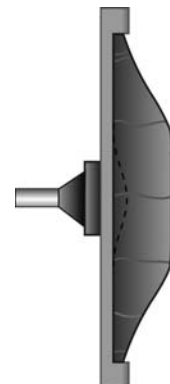

4. Sand the foot to 400 grit.
5. Add detailing, if desired.
6. Sand to 600 grit and apply sealer.
7. Remove from lathe and sign your name.

### Finished Platter

I use both an oil/varnish mix and a lacquer finish on my platters. Which one I use, depends on the wood I am turning. I usually prefer oil/varnish on dark woods and lacquer on light woods. The oil/varnish mix consists of 1/3 pure tung oil, 1/3 polyurethane and 1/3 mineral spirits. I use this over an oil based sanding sealer. I use spray lacquer from a can over lacquer sanding sealer, which I apply with a paper towel.

I find that the most important part of finishing is a thorough and careful sanding job.



**Front**

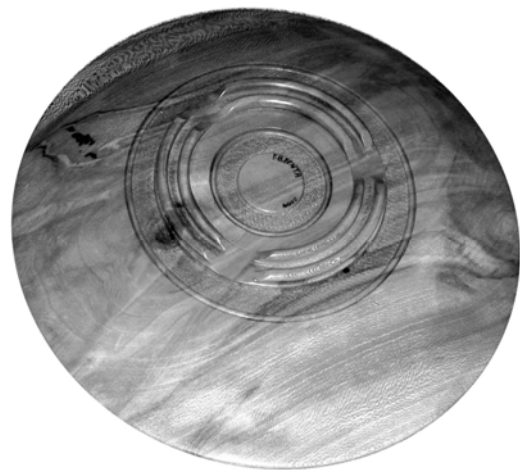

**Back**